



Marine & Offshore
CRANE SOLUTIONS

Protect Boom Lacings from Hook Strikes

ALATAS Designed Bumper Bars





Marine & Offshore CRANE SOLUTIONS

ALATAS has designed a bumper bar system that fully protects all lattice crane booms from hook strikes. The installation is fully DROPS compliant .

We have installed the bumper bars on numerous crane types over the years with excellent results and feedback from our customers.

To name a few, will be as follows:

- Favelle Favco : 6/10K (AL:A1404-000-000)
- Favelle Favco : 7.5/10K (AL:A0150-000-000 / AL:A0160-600-000)
- Favelle Favco : PC250 (AL:A0165-400-000)
- NOV 60 (AL:A0164-400-000)

Bumper Bars are well constructed with high tensile steel, attached with rubber layered clamping flanges and heavy duty D-Profile rubber bumper . The complete system is 100% drops compliant. All bolts are Galvanized, Nuts are Nylon Self Locknuts & all washers/ spring washers are NORD-LOCK. The complete system also come with lanyard & accessories. The unit is finally sandblasted and painted with a 3-layer marine grade paint.

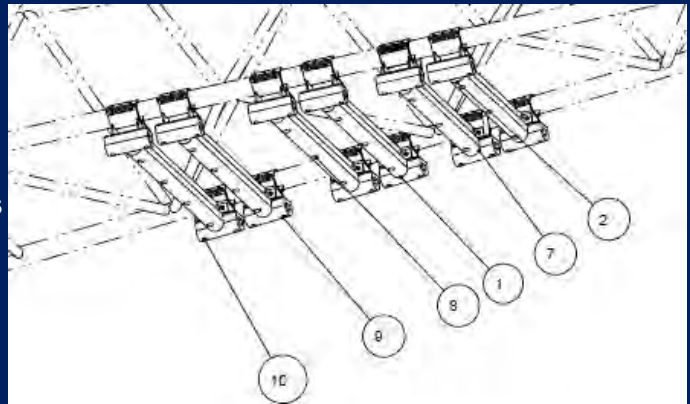

Fig 1. Bumper Bar set on 6/10K Crane

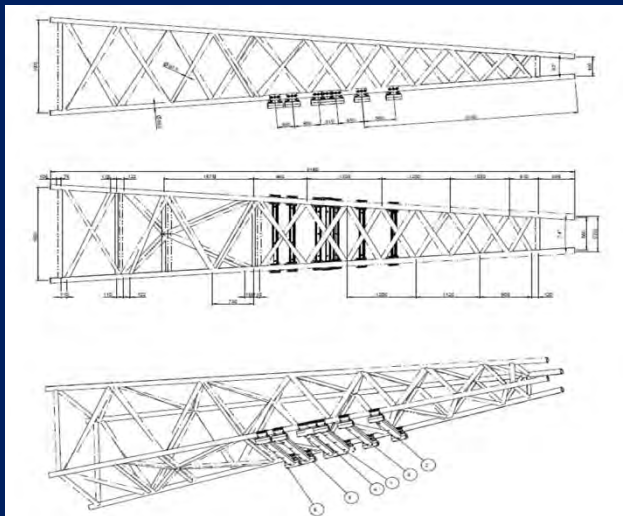

Fig 2. 6/10K Crane)

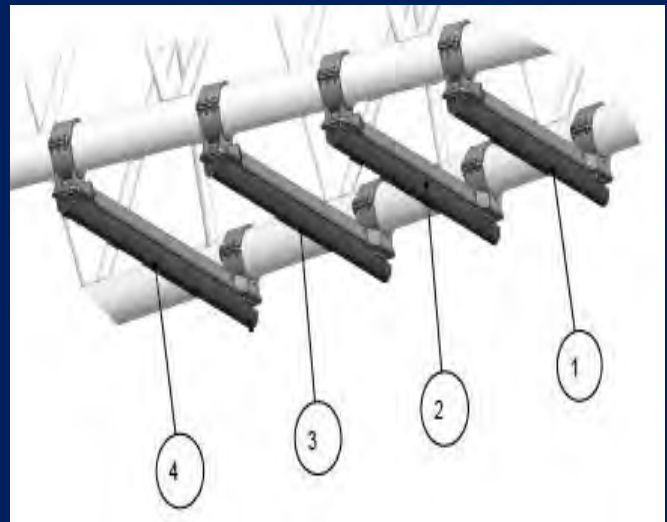

Fig 3. Bumper Bar set on PC250